

3 and 4 Gang Digilux

Modular Lighting Control

Installation Manual

Contents:

1 x Digilux control back box

2 x M3.5mm fixing screws

1 x Polycarbonate faceplate

Compliance and Standards:

The Digilux products use a IEEE 802.15.4 Zigbee mesh network to build and secure communications between all end points to allow wireless control.

The product complies with all the basic requirements and other relevant provisions of the 1999/5/EC directive using TUV CE standard and process. For full details of this please contact support@orcomm.com.

Operation is subject to the following two conditions:

(1). This device may not cause harmful interference, and (2) this device must accept and interference received, including that may cause undesired operation.

Installation of the product must be carried out by a qualified person conforming to all standards set out by law of installed country.



Installation:

Mounting the control back box:

Install and fix a suitable electrical back box where the unit is to be located. This back box should be a minimum of 40mm deep (47mm is recommended to ease installation).

Please take care to remove top and bottom tabs of any steel back box being used to prevent contact with the housing and terminals.

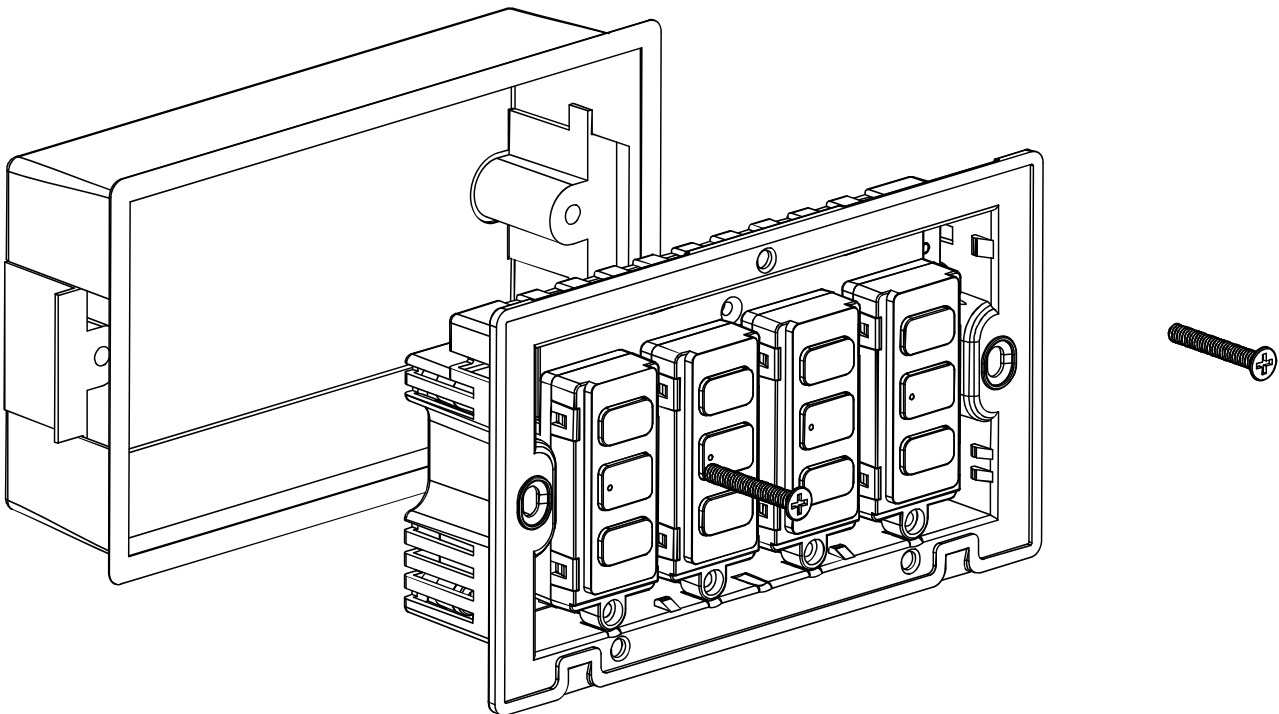

Once connections and terminations are complete, secure with the provided M3.5mm PH2 drive screws.

Connections:

BEFORE ANY TERMINATIONS, PLEASE ENSURE THAT ALL POWER IS REMOVED FROM ANY LINES.

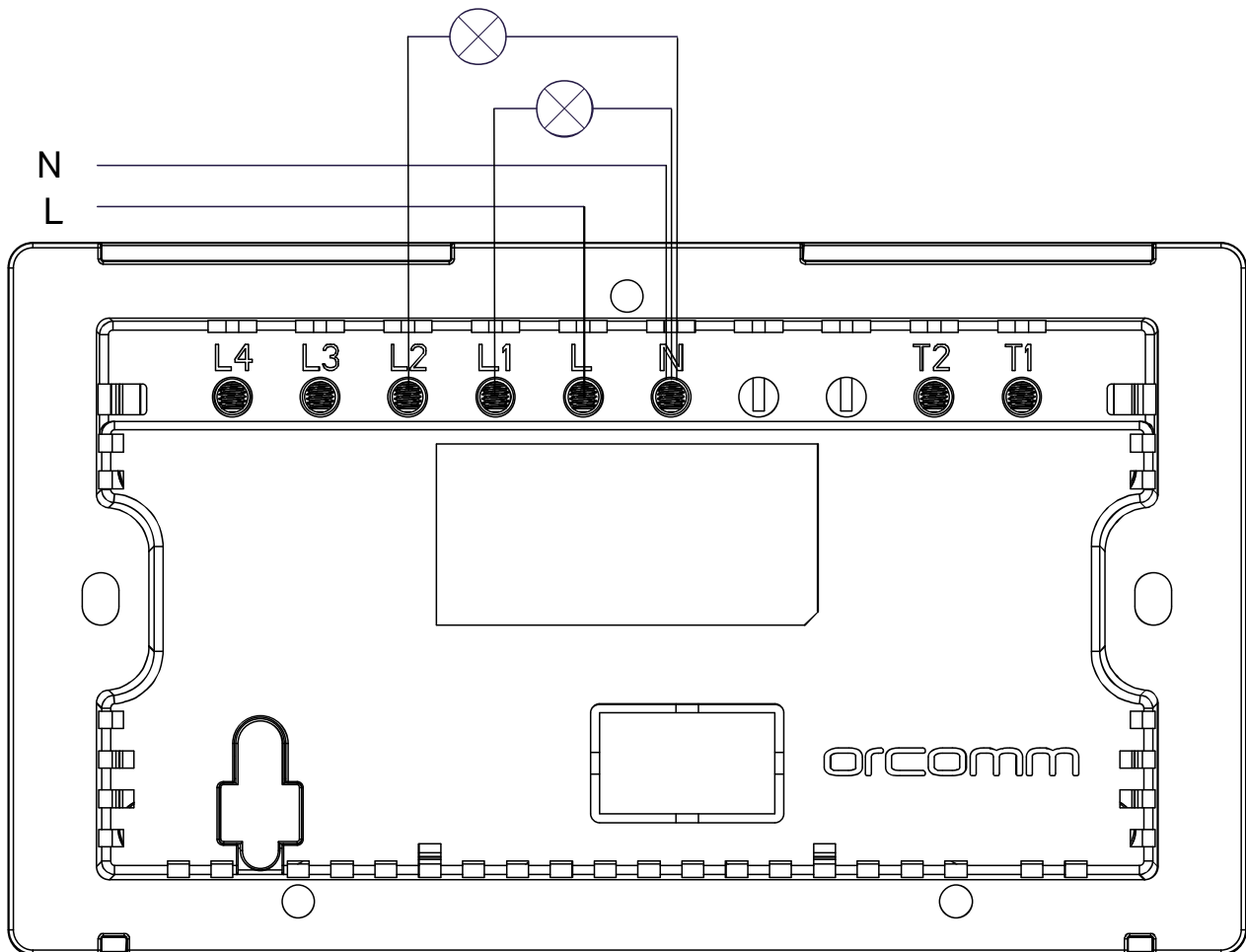

Please ensure that all terminals are secured tightly as per electrical installation standards.

Modules:

Once the control back box has been installed and connected, the unit is ready to be installed with the switch or dimmer modules (sold separately). A combination of modules can be used on the same control back box.

Please make sure that NO power is being fed to the lighting circuit until all modules have been installed.

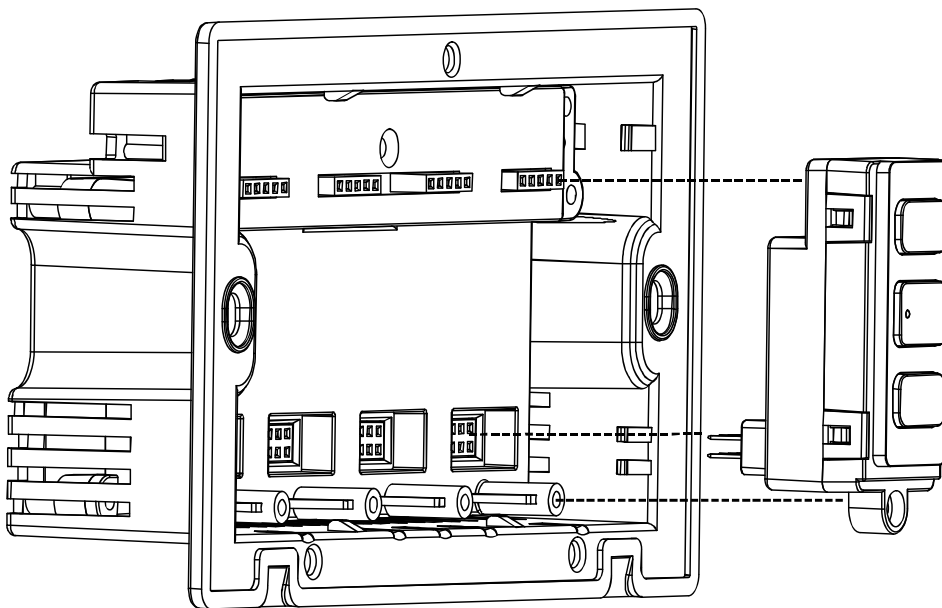

During installation of the modules, care should be taken to ensure that the connecting pins are lined up and straight before fully inserting. Please DO NOT continually remove and install the modules.

Once the module is installed, secure with the screw provided.

Module Assignment:

You are able to mix different modules in different locations within the control back box. Please ensure that you match the channel with the correct terminal on the rear of the device.

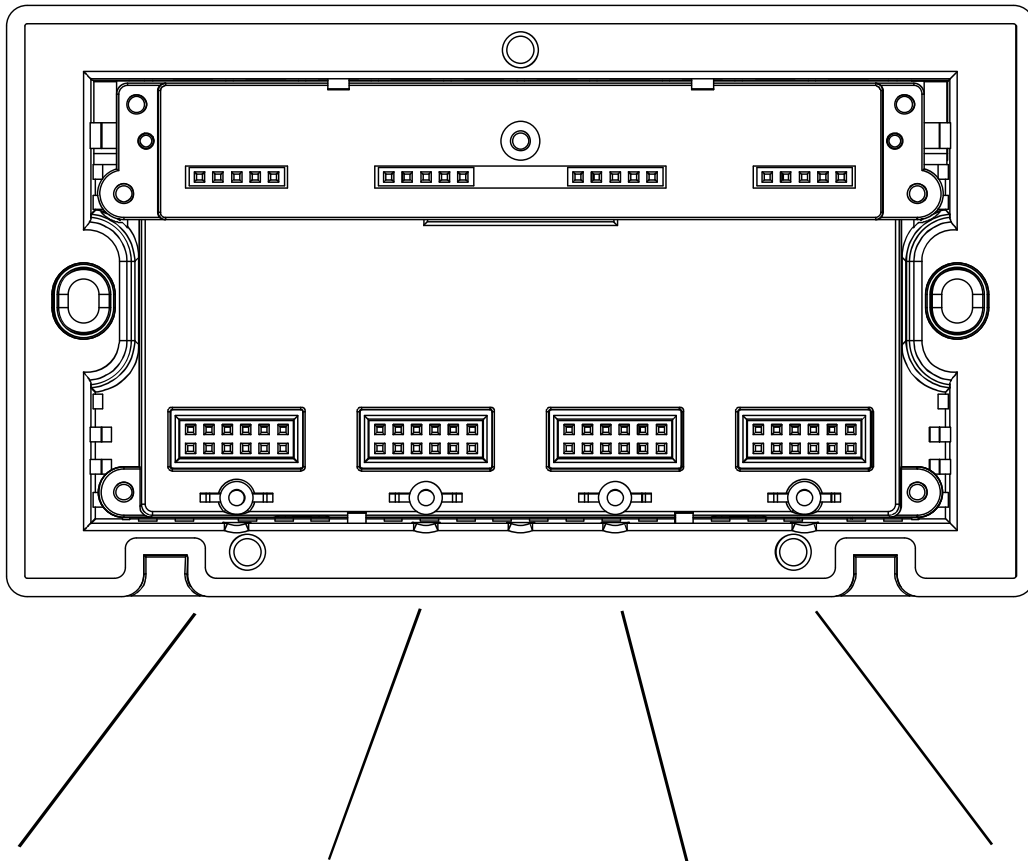

Module Channel 1	Module Channel 2	Module Channel 3	Module Channel 4
Back Terminal - L1	Back Terminal - L2	Back Terminal - L3	Back Terminal - L4

Maximun load: Switch Module = 150W / Dimmer Module = 150W

Faceplate:

Once all modules have been installed, the faceplate can be inserted.
Please ensure that the locating tabs are aligned before setting into position.

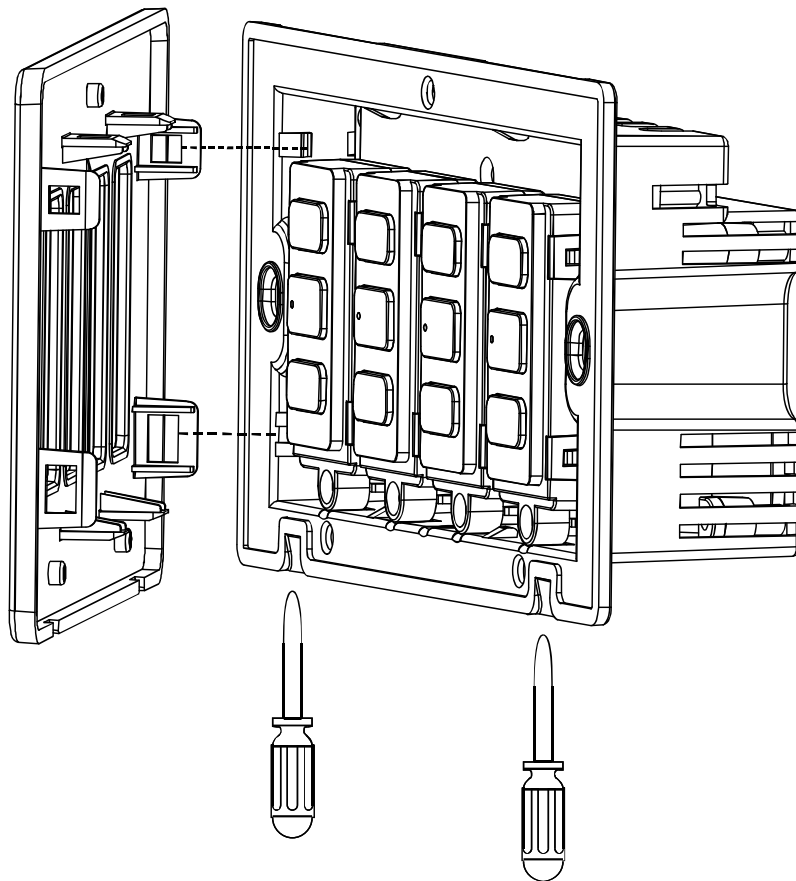

Removing the faceplate can be done using a small 4-6mm flat blade screw driver.

Where possible, secure the back box against the wall while levering the faceplate off to prevent box being pulled away from the wall.

Warranty:

Orcomm provides warranty for this product against defects due to workmanship or materials, but does not cover damage or breakdown due to; normal wear and tear, abuse, improper maintenance, disassembly of parts, scratches to the finish (normal wear and tear), attempted repair, natural disaster and force majeure.

The warranty excludes among other item; installation, providing access to products and special incidental and consequential damages. (Loss of revenue / profits, damages to property or miscellaneous cost not previously mentioned).

Subject to the conditions as set forth by the "Conditions of warranty" and set forth hereunder, the purchaser receives the RTB warranty for the applicable period of 2 years.

Conditions of Warranty:

This warranty covers products within their intended or normal use as defined by the following:

- Operation conditions are in accordance with the information on the product, datasheet and its packaging.
- The warranty period starts from the date of invoice.
- The products have been properly installed and operated in accordance with the manufacturer's instructions.
- Adequate records of operating history are retained and available to the manufacturer for review.
- We will have access to the defective product, if the product or other components become suspect, then we have the right to evaluate the lighting system with the assistance of a third party.
- Ambient temperature never exceeds the operation temperature range of -10°C to +40°C.
- Relative humidity in the installation location never exceeds the range of 20% - 85% RH.
- Products are not subjected to more than 50,000 switched cycles.
- The electrical installation in which the product operates is not subjected to voltage fluctuations in a range exceeding 230 VAC +/- 10%.
- Labour cost for installation or de-installation of the products are not covered under this warranty.
- Orcomm cannot be held liable for electrical supply conditions, including spikes, over / under voltage and ripple current control systems that are beyond the specific limits of our products and those defined by relevant installation and environmental standards.

Warranty Claims:

Orcomm Warranty claims have to be reported to Orcomm within 20 days of discovery, specifying the following information: Part code, batch number, installation date, number and percentage of failures, application, hours used and estimated number of cycles.

Maintenance of Devices:

Keep the surface clean with a dry cloth or appropriate cleaner containing no acids, benzene, thinners or solvents. The use of the above may cause damage to the casing or the surface finish / colour.

Failure to follow these directions, could invalidate all warranties.

Returns Policy:

Return shipping even if the item is defective should be paid for by the buyer.

We do not provide any refunds as per our terms of sales.

Full details of returns are covered in our standard terms of sales agreed to upon account opening.

Operating and further information:

Full operation and user manuals are available from www.orcomm.com/downloads

Support and Aftercare:

In the event of support or aftercare please email support@orcomm.com

Dimming Performance:

Orcomm cannot be held liable for dimming performance due to 3rd party lamps, environmental factors, power supply and site configurations.

It is highly advised that the performance testing is undertaken with the chosen light sources, before permanent installation takes place.