

ORC-E2V3 / E3V3 / E5

Door Entry Panels

Quick Connection Diagram v2.1

Contents

Introduction	2
ORC E - V3 range connection overview.....	2
Door Panel Connections.....	3
12V DC Power.....	3
Network Connection	3
Optional	3
Wiegand reader to Access Controller	3
Local Door Contact / Press to Exit	4
Using Relay on Door Panel for PTE input on Access Controller	4
ORC-UM-R	5
Brief Description.....	5
Technical Characteristics	5
Timer (Relay 1).....	5
Unused Wires	5
Terminal Connections	6
Standard Wiring	6
RS485 Wiring	6
Exit Wiring.....	6
Relay 1 options.....	7
Access Control / 3 rd Party devices.....	7
Fails Safe	7
Fail Secure.....	7

Introduction

Please note, this guide is intended for installation and commissioning partners.

ORC E - V3 range connection overview

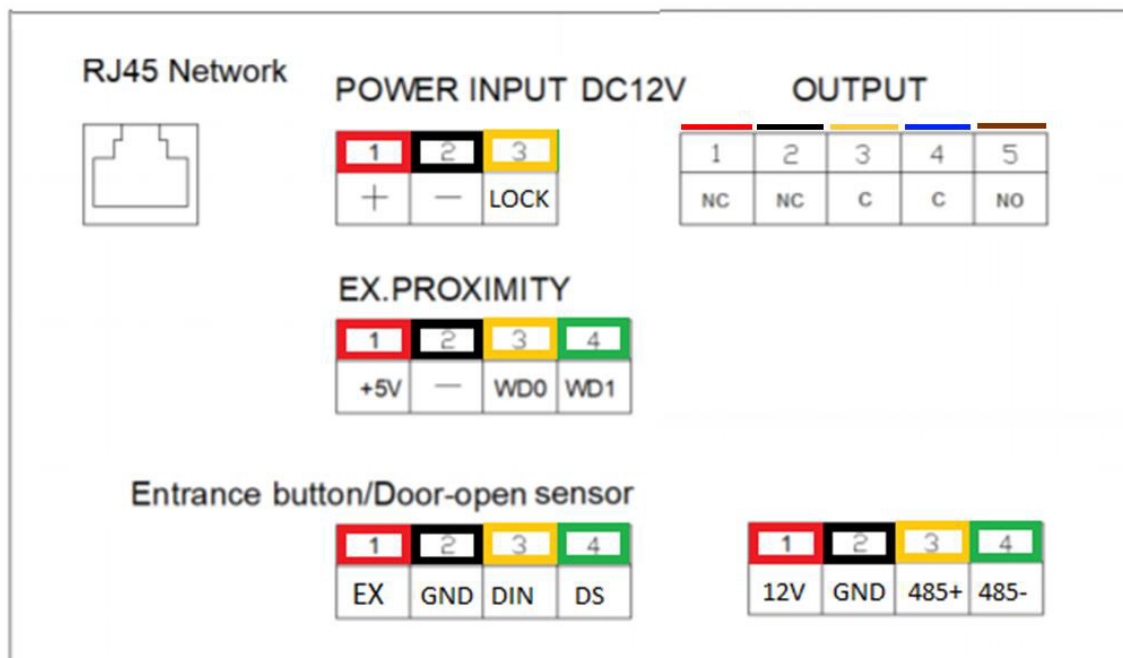

Fig 1

Door Panel Connections

12V DC Power

Connect the 12V DC power Supply to the input of the Door Panel.

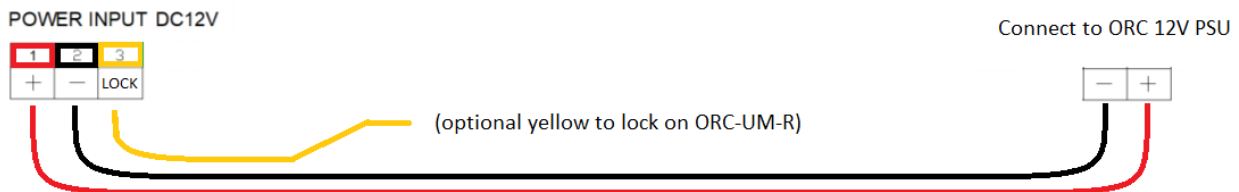

Fig 2

Network Connection

Connect the Ethernet to a network switch



Fig 3

Optional

Wiegand reader to Access Controller

Connect the GND, WD0 & WD1 to GND, D0 and D1 of the Access Controller (Wiegand 26-bit)

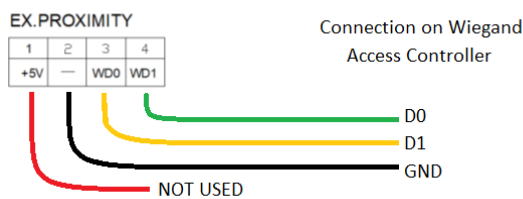

Fig 4

WARNING do not connect 5V (RED) to access controller

Local Door Contact / Press to Exit

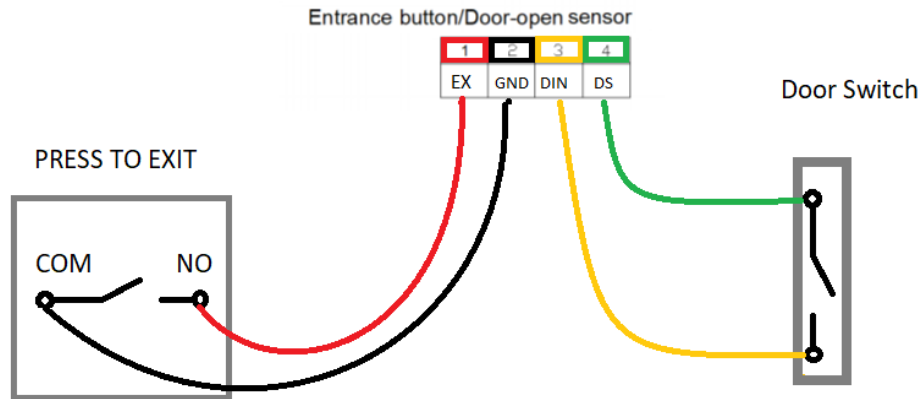

Fig 5

Using Relay on Door Panel for PTE input on Access Controller

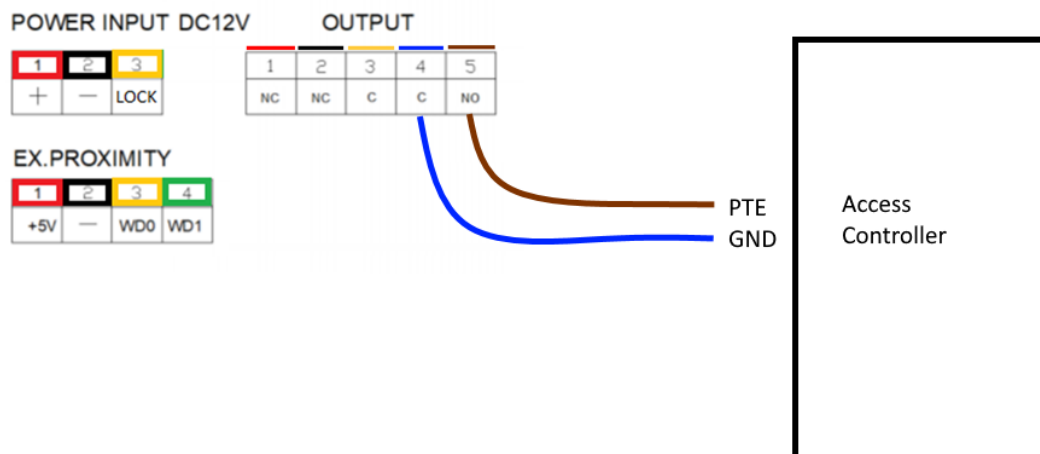

Fig 6

ORC-UM-R

Quick Connection Diagram

ORC-UM-R

Brief Description

The ORC-UM-R is a multipurpose Relay designed to work along side Orcomm external call panels, ORC-E2, ORC-E3, ORC-E5.

When the door release command is pressed on the intercom screen, the Door Panel will send a signal either through LOCK or RS485. Relay 1 will operate for a time. Note Timer for Relay 1 can be changed via the Potentiometer.

Technical Characteristics

- Secure By Design (Must be wired secure side of Door - i.e. Riser cupboard)
- 12V DC (1W)
- Working Temperature: -40 ~ +70 C
- Humidity: 20 ~ 80%
- Size: 115 x 58 x 34 mm
- Relay Max
 - 1A (230V AC)
 - 5A (24V DC)
 - 10A (12V DC)

Timer (Relay 1)

Relay 1 - Timer adjustment - Potentiometer

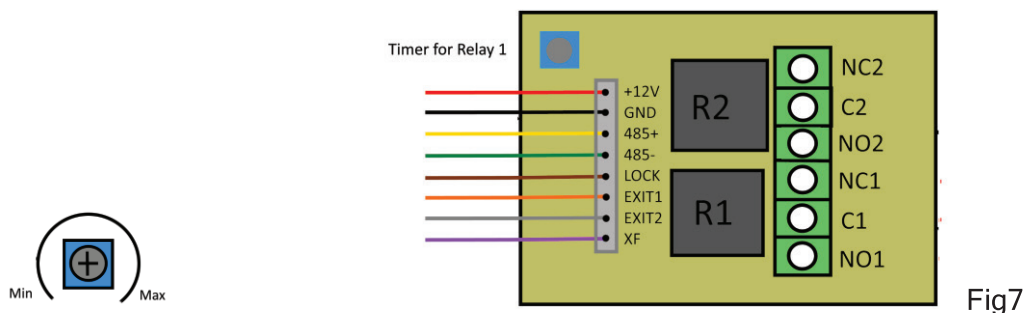

Fig7

Unused Wires

Warning all wires unused must be insulated to stop accidental triggering or damage to the ORC-UM-R and/or External Door Panel.

Terminal Connections

Standard Wiring

Connect the ORC-UM-R with 12V, GND and LOCK between Door Panel and Riser

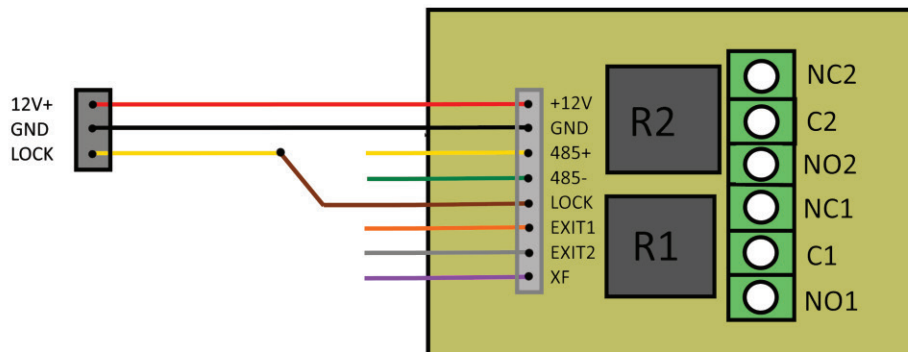

Fig 8

RS485 Wiring

Connect the ORC-UM-R with RS485 when installation requires encryption between Door Panel and Riser (i.e. Secure By Design)

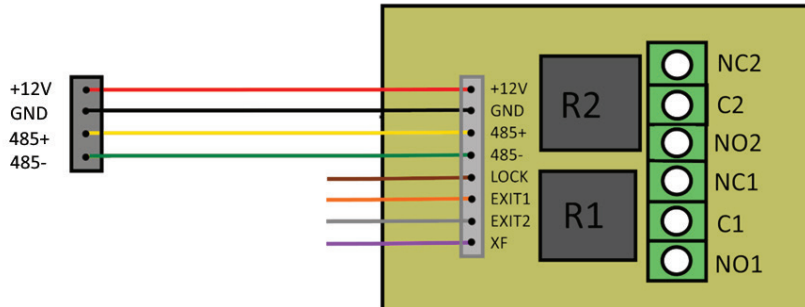

Fig 9

Exit Wiring

Temporarily connect "Exit 1" terminal to "GND" to start Relay 1 Timer

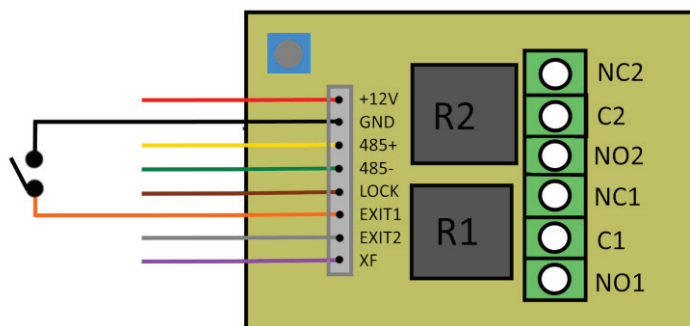

Fig 10

Relay 1 options

There are several options to wire the relay contact terminals.

Access Control / 3rd Party devices

The below diagram will send a short signal (close contact on trigger). Commonly used with Access Controllers (GND and PTE), or IN1 & IN2 on Automatic door / gates.

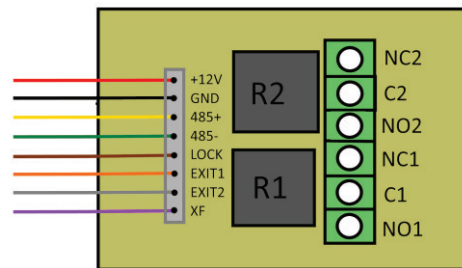

Fig 11

Fails Safe

The below diagram will open the relay contact on trigger from Video Door Entry System. Commonly used with Fail safe locks (Remove power to open).

Note ORC-UM-R (is designed for fire applications - thus NO1 = normally closed)

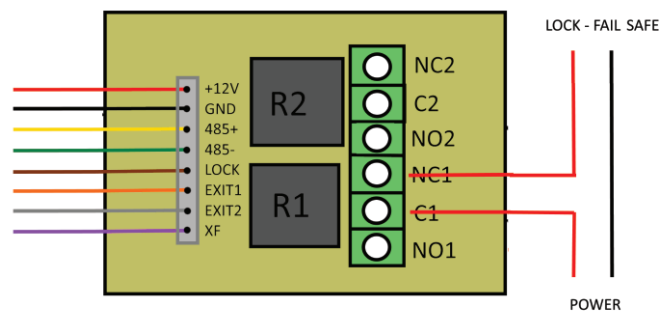

Fig 12

Fail Secure

The below diagram will close the relay contact on trigger from Video Door Entry System. Commonly used with Fail secure locks (Power to open).

Note ORC-UM-R (is designed for fire applications - thus NO1 = normally closed)

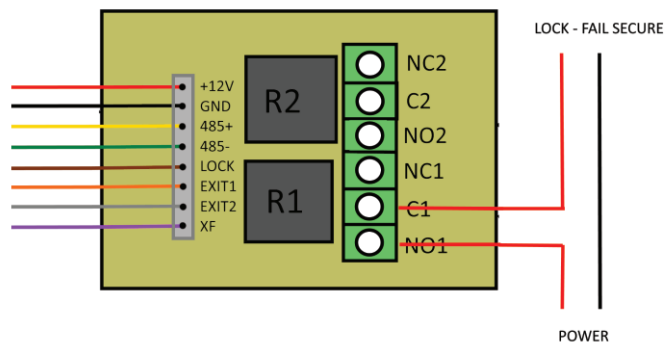

Fig 13